

Round or Square Type Non-IC, Chicago Plenum Down Light Housing with CMH Electronic Ballast

E3_-C_D_ 1.0



ELEMENT

GENERAL PRODUCT INFORMATION:

This instruction shows a typical installation.

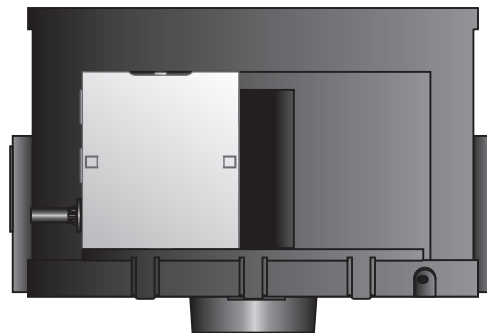

SAVE THESE INSTRUCTIONS!

CAUTION - RISK OF FIRE
This product must be installed in accordance with the applicable installation code by a person familiar with the construction and operation of the product and the hazards involved.
Use minimum 90°C supply conductors.

Install the Housing with Adjustable Bars

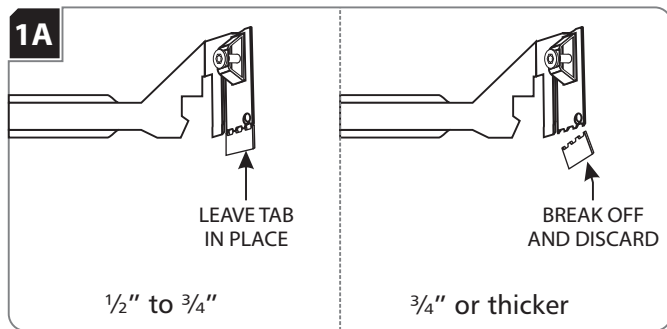

NOTE: Skip this section if installing the housing with butterfly brackets.

- 1** Keep Tab for ceiling 1/2" to 3/4" thick. When using adjustable hanger bars with 1/2" to 3/4" thick ceilings, leave the tab of the hanger bars in place. **Break off Tab for ceiling 3/4" or thicker.** When using adjustable hanger bars with 3/4" or thicker ceilings, remove the tab by bending it at the perforation.

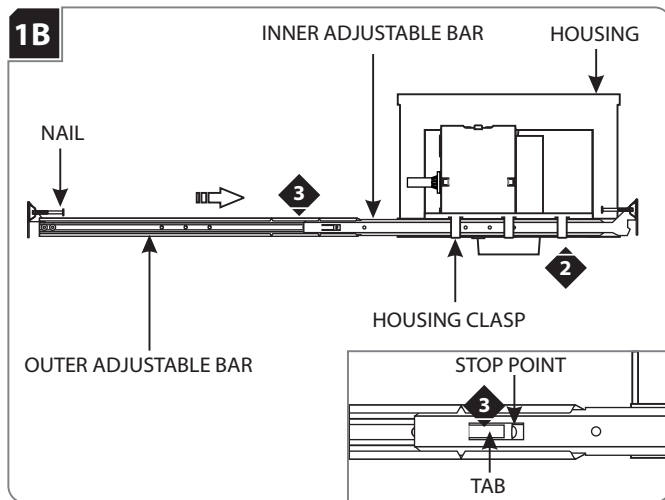

- 2** Slide the inner adjustable bar completely through the three housing clasps. Make sure the nail is on top.
- 3** Slide and push the outer adjustable bar completely onto the inner adjustable bar so that the tab clicks into place behind the stop point. This will prevent the adjustable bars from coming apart.
- 4** Repeat steps 2 & 3 for the other side of the housing.

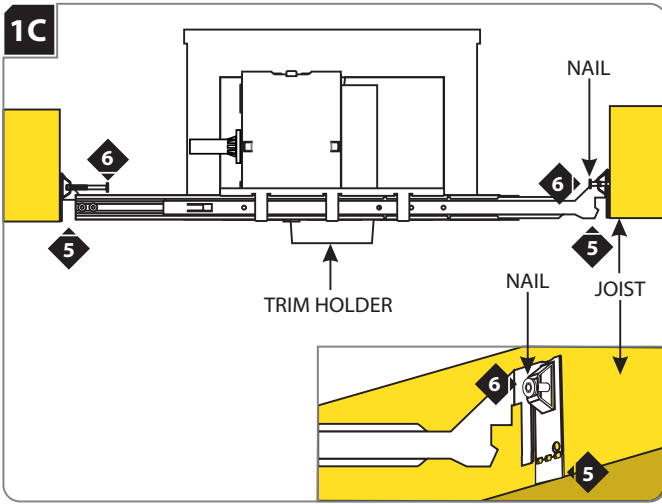

NOTE: The adjustable bars can be mounted to joists that are spaced 16" - 24" apart.

- 5 Align the bottom of the end plates with the bottom of the ceiling joists.
- 6 Level the adjustable bars and, with a hammer, tap the nails completely into the joists to secure the adjustable bars.

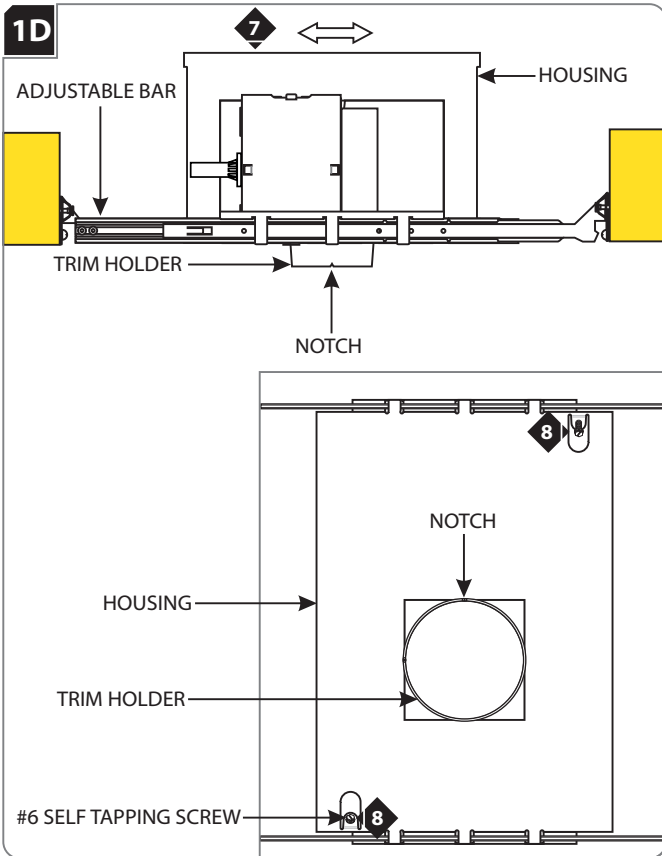

- 7 Adjust the trim holder position (horizontal position) by sliding the housing on adjustable bars.
- 8 When the desired location is achieved, tighten the two #6 self tapping screws to lock the housing onto the adjustable bars.

TIP: Notches in trim holder can be used to align multiple housings using a laser or string.

Install the Housing with Butterfly Brackets (Non-IC Housing)

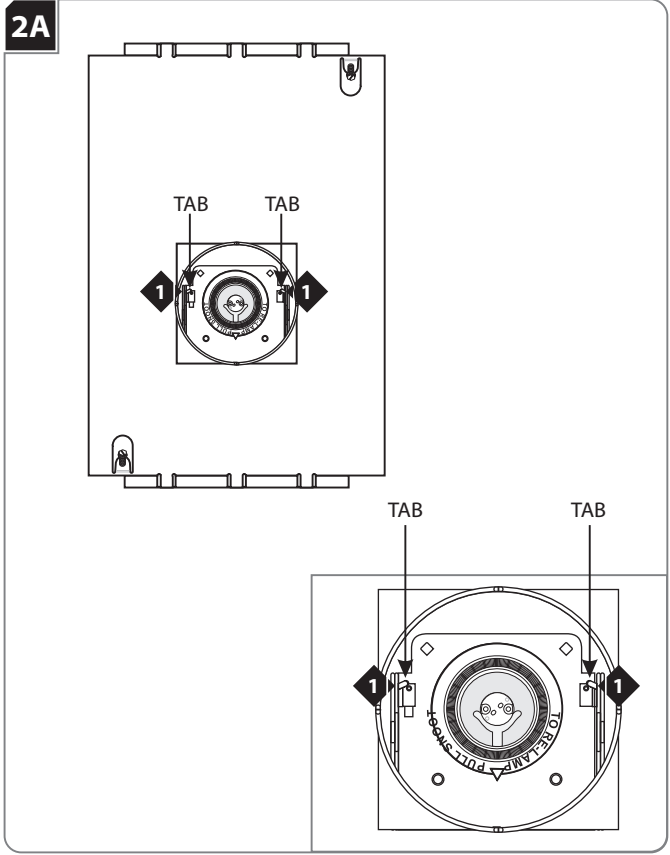

NOTE: Skip this section if installing the housing with butterfly brackets.

- 1 Squeeze the two tabs on the lamp housing to unsnap it.
- 2 Swing the lamp housing back.

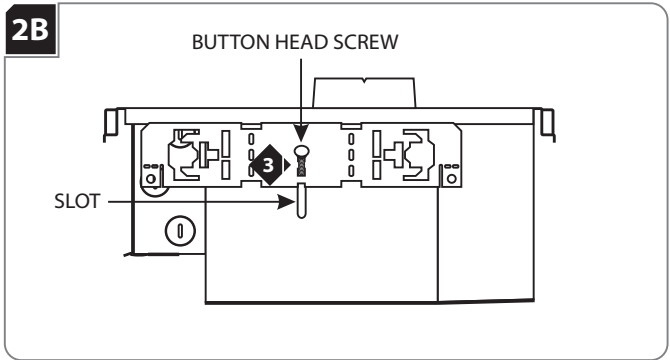

- 3 Place the button head screw through the square cut out of the butterfly bracket into the housing slot.

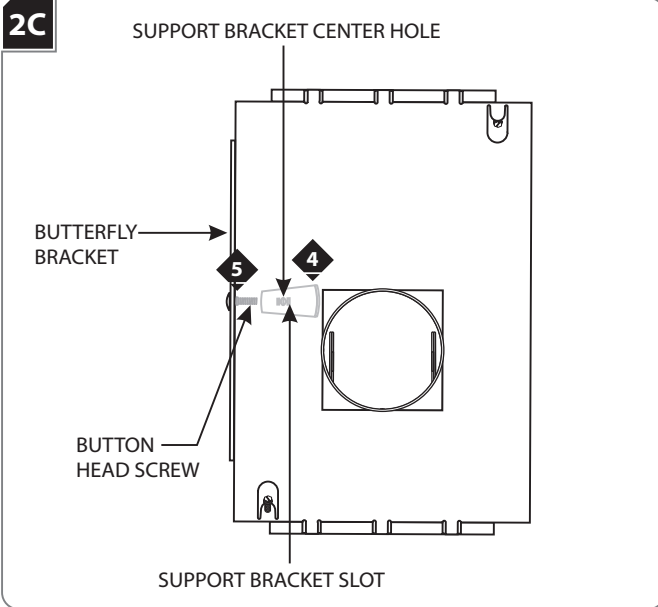

- 4 Place the support bracket center hole onto the button head screw.
- 5 Push the support bracket slots against the butterfly bracket tabs.

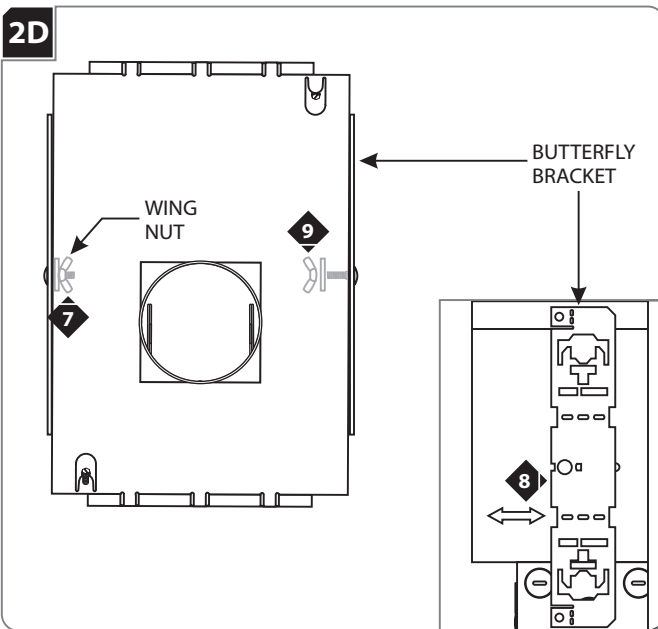

- 6 Attach the wing nut loosely to the button head screw.
- 7 Slide the butterfly bracket up or down to achieve the proper location. Tighten the wing nut to secure the butterfly bracket in place.
- 8 Repeat steps 3 through 7 on for the other butterfly bracket.
- 9 Swing the lamp housing down until the tabs lock it in place (reversal of steps 1 and 2).
- 10 Utilize the butterfly brackets to install the housing in accordance with local electrical codes.

NOTE: Notches in trim holder can be used to align multiple housings using a laser or string.

Install the Housing with Butterfly Brackets (Chicago Plenum Housing)

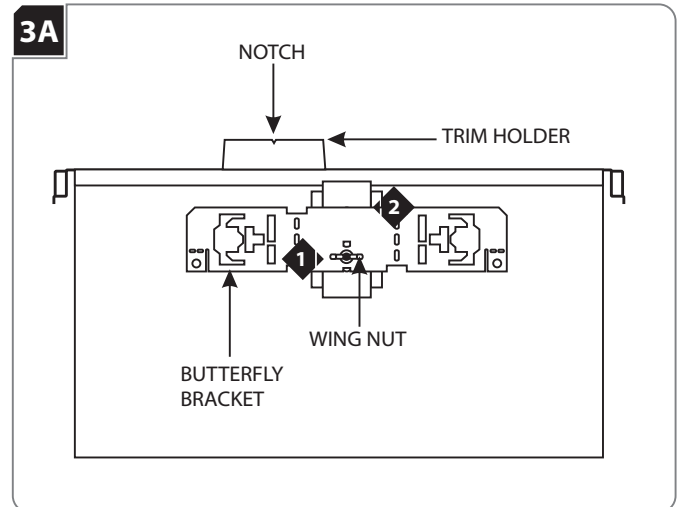

NOTE: Skip this section if installing the housing with adjustable bars.

- 1 Slightly loosen the wing nut to slide the butterfly bracket up or down.
- 2 After achieving the proper location, tighten the wing nut to secure the butterfly bracket in place.
- 3 Repeat steps 1 and 2 on for the other butterfly bracket.
- 4 Utilize the butterfly brackets to install the housing in accordance with local electrical codes.

NOTE: Notches in trim holder can be used to align multiple housings using a laser or string.

Connect Power to the Housing

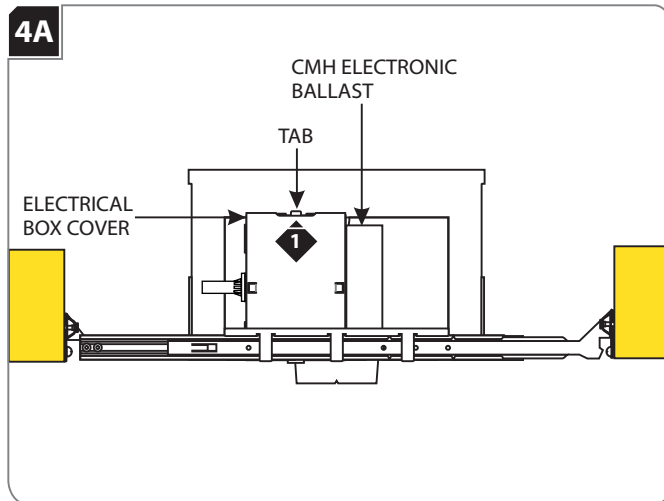

- 1 Push up on the tabs on the electrical box and remove the electrical box cover.

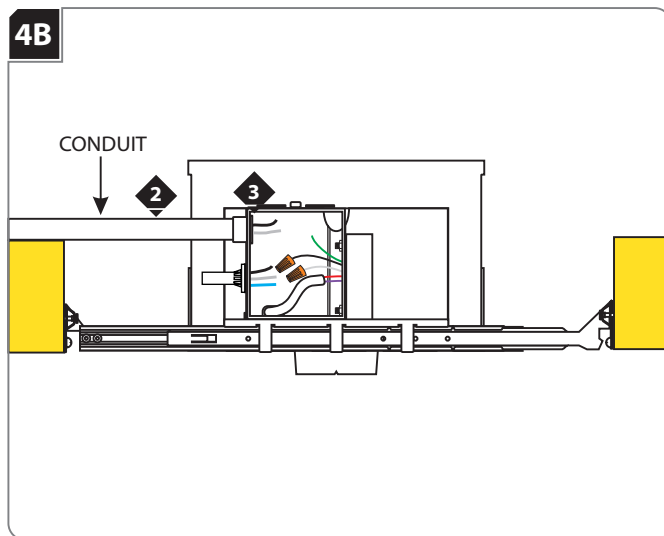

- 2 Install the conduit to the housing electrical box.
- 3 Run the power line wires into the housing electrical box.

NOTE: When a fixture is installed in a location that requires servicing from below the ceiling through the fixture aperture, the branch circuit connections need to be able to be brought out through the aperture. To accomplish this, an NM type cable in conjunction with snap-in/push-in connectors must be used and a 12" service loop must be left available outside of the fixture housing wiring compartment to allow additional branch circuit wiring to be pulled through the snap-in/push-in connector and extended out through the aperture below ceiling level.

WARNING: RISK OF FIRE: When using the housing electrical box for power feed through, use **MAX** 4 - #12 AWG, or 6 - #14 AWG branch circuit wires.

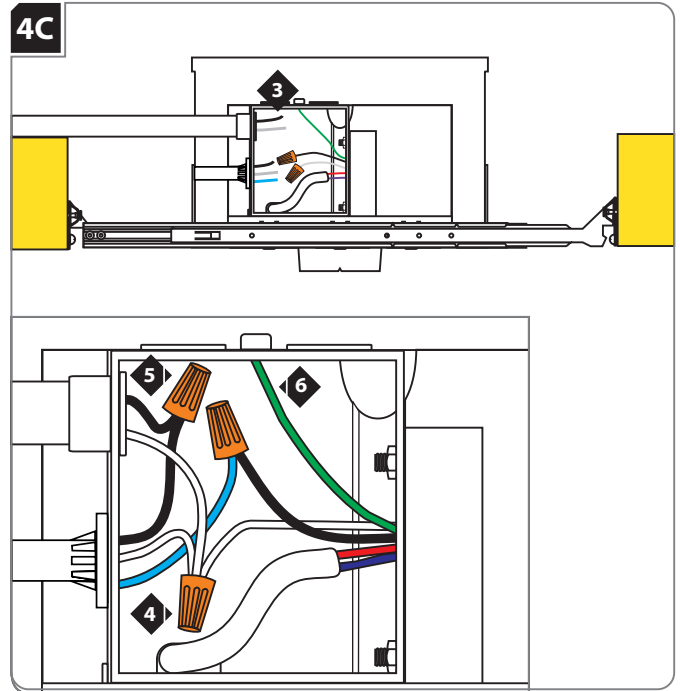

- 4 Connect the neutral power line wire to the white transformer wire and the white thermal protector wire with a wire nut.
- 5 Connect the hot power line wire to the black thermal protector wire with a wire nut.
- 6 Make sure that housing is grounded in accordance with local electrical codes.
- 7 Replace the electrical box cover. Make sure that the top edge of the cover snaps under the tab.

Install the Lamp & Lens Accessories

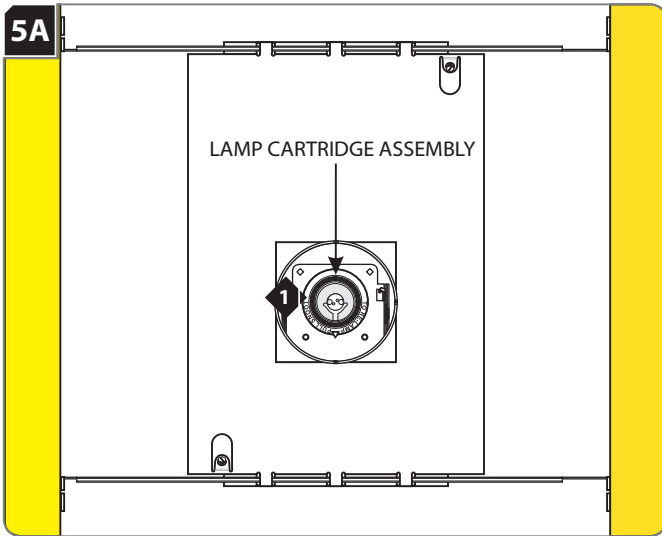

1 Pull the snout to remove the lamp cartridge assembly.

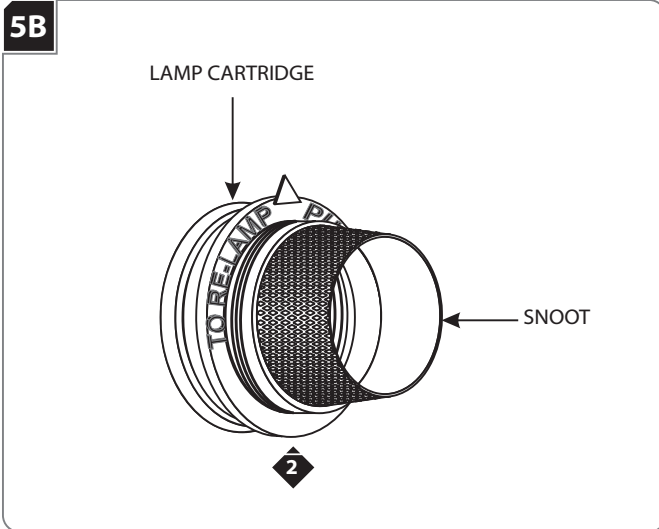

2 Unscrew the snout from the lamp cartridge.

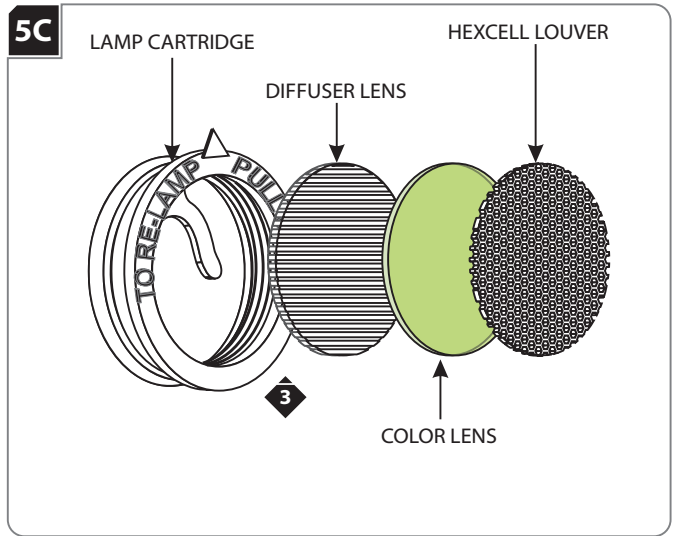

3 Place a maximum of three accessories (optional) into the lamp cartridge.

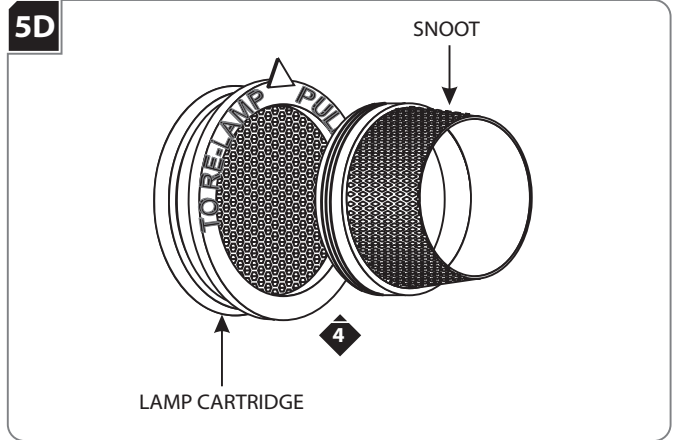

4 Replace and tighten the snout completely to the lamp cartridge.

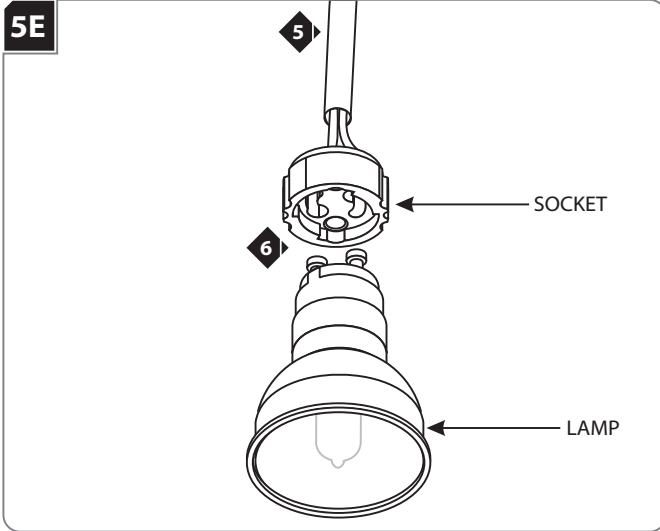

Use **ONLY** 120 Volt, **20 Watt** GX10 Base MR16 Ceramic Metal Halide lamp with models E3RLB-C20DC_, E3RLF-C20DC_, E3SLB-C20DC_, E3SLF-C20DC_.



Use **ONLY** 120 Volt, **39 Watt** GX10 Base MR16 Ceramic Metal Halide lamp with models E3RLB-C39DC_, E3RLF-C39DC_, E3SLB-C39DC_, E3SLF-C39DC_.



- 5 Pull out the socket from the lamp housing.
- 6 Push the lamp pins into the large portion of the socket slots and rotate the lamp clockwise to lock it in place securely.

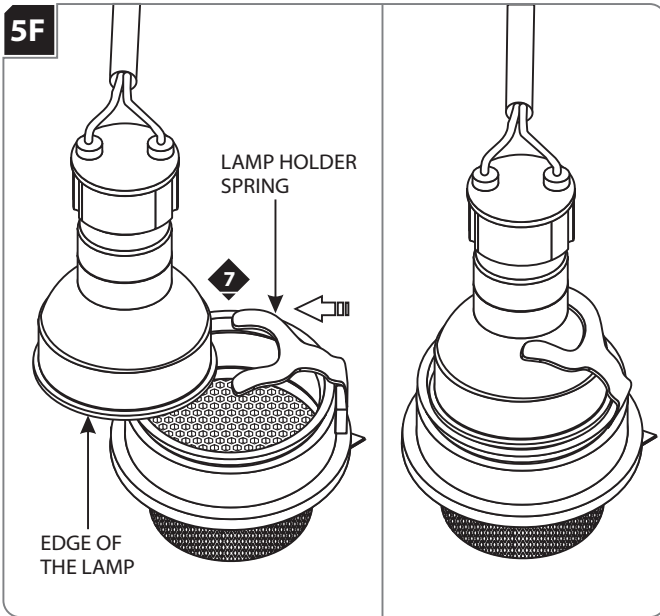

- 7 Slide the lamp holder spring completely onto back of the MR16 lamp so that the edge of the lamp snaps into the lamp cartridge assembly.

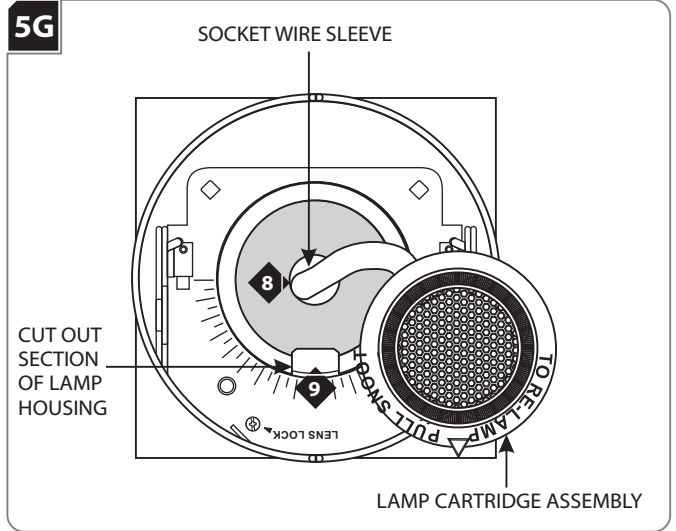

- 8 Feed the socket wire sleeve back into the lamp housing.
- 9 Align the arrow indicator on the lamp cartridge assembly with the cut out section of the lamp housing. Push to snap the lamp cartridge assembly into the lamp housing.

TIP: Before installing ceiling, power up and run the Element fixture(s) for 10 minutes to make sure all electrical connections are tight.

Install Drywall

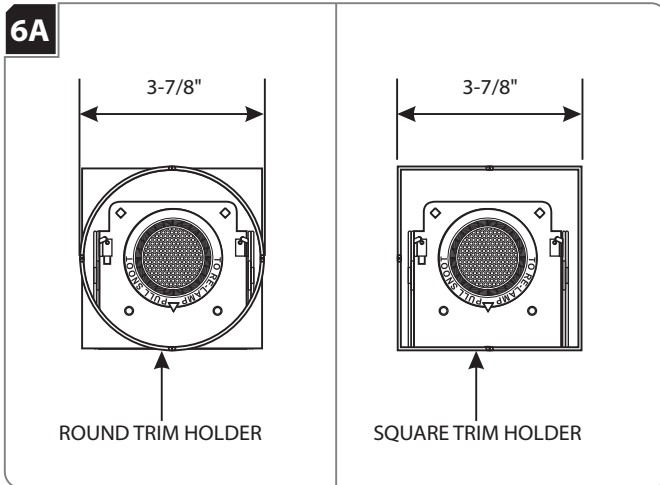

- 1** For round trims, mark a 3-7/8" diameter circle on drywall. Cut out the marked section.
For square trims, mark a 3-7/8" square on drywall. Cut out the marked section.

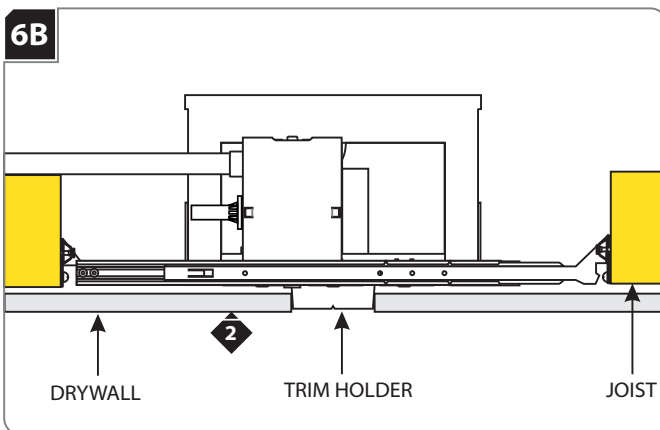

- 2** Align the cut out section of drywall with the trim holder and install drywall.

WARNING: Risk of Fire: The housing is not intended to be in contact with or covered with combustible materials and insulation. Do not install insulation within 3 inches of the housing sides or above in such a manner to entrap heat.

Install the Plaster Ring (for Flangeless Versions)

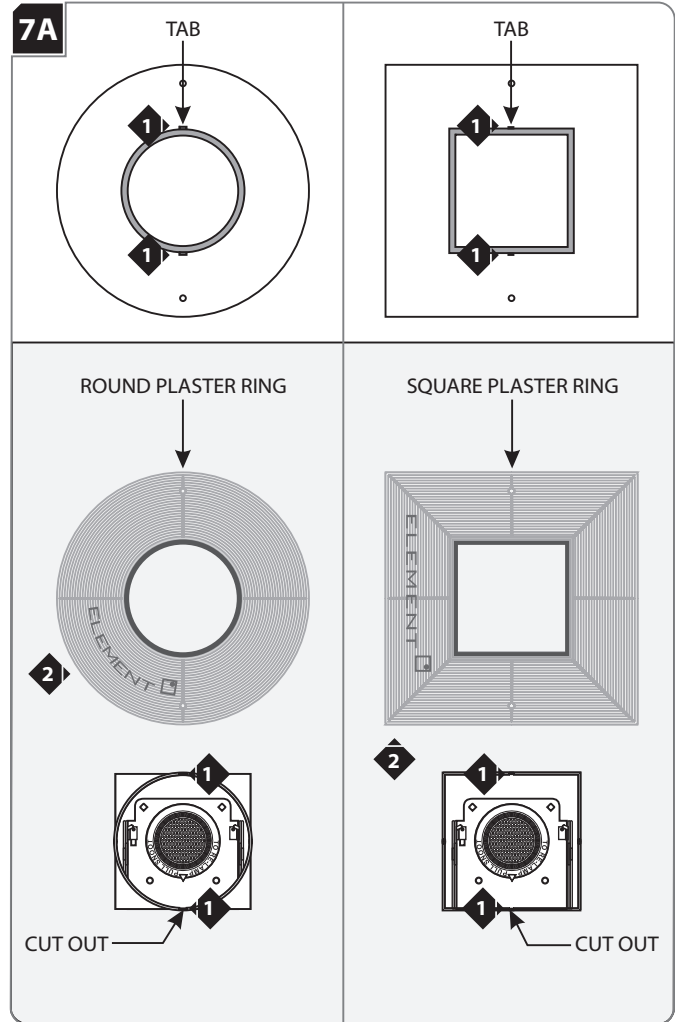

- 1** Line up the two tabs in back of the plaster ring with the two cut out sections of the trim holder inside edge.
2 Push the plaster ring tabs into the cut out sections of the trim holder edge.

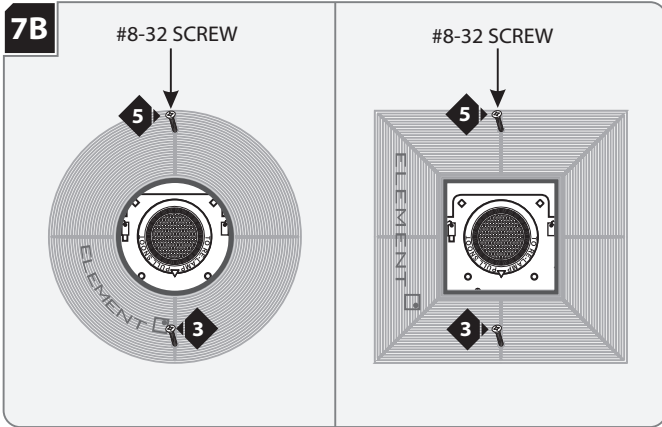

- 3 Secure the plaster ring in place with the two provided flat head #8-32 screws. Make sure that the screws penetrate through the drywall into the housing screw holes.

NOTE: Do not overtighten the screws! Overtightening may bend the plaster ring, causing the plaster surface to come away from the drywall.

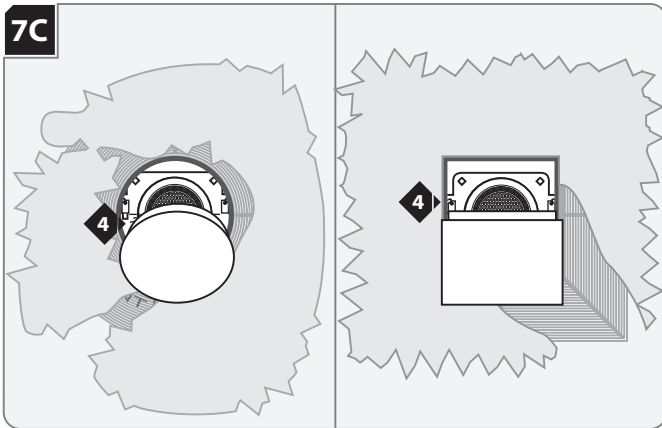

- 4 Plug the trim holder with the provided dust shield.
- 5 Properly plaster onto the plaster ring and drywall.

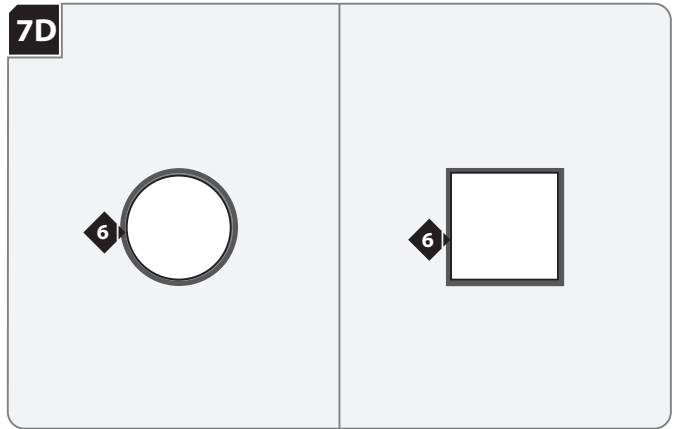

- 6 Finish around the trim to match drywall.